

VIEW 1
SCALE 3 / 4

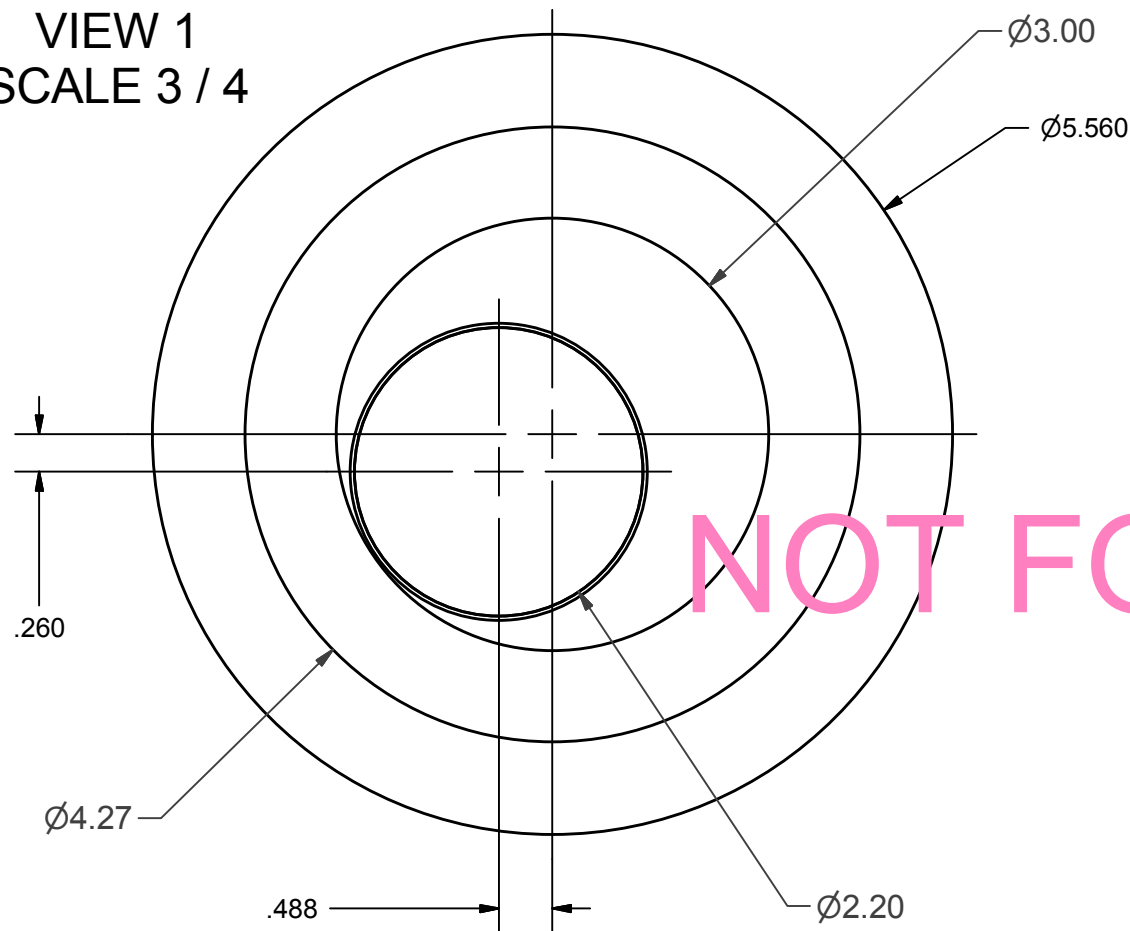

VIEW 2



VIEW 3

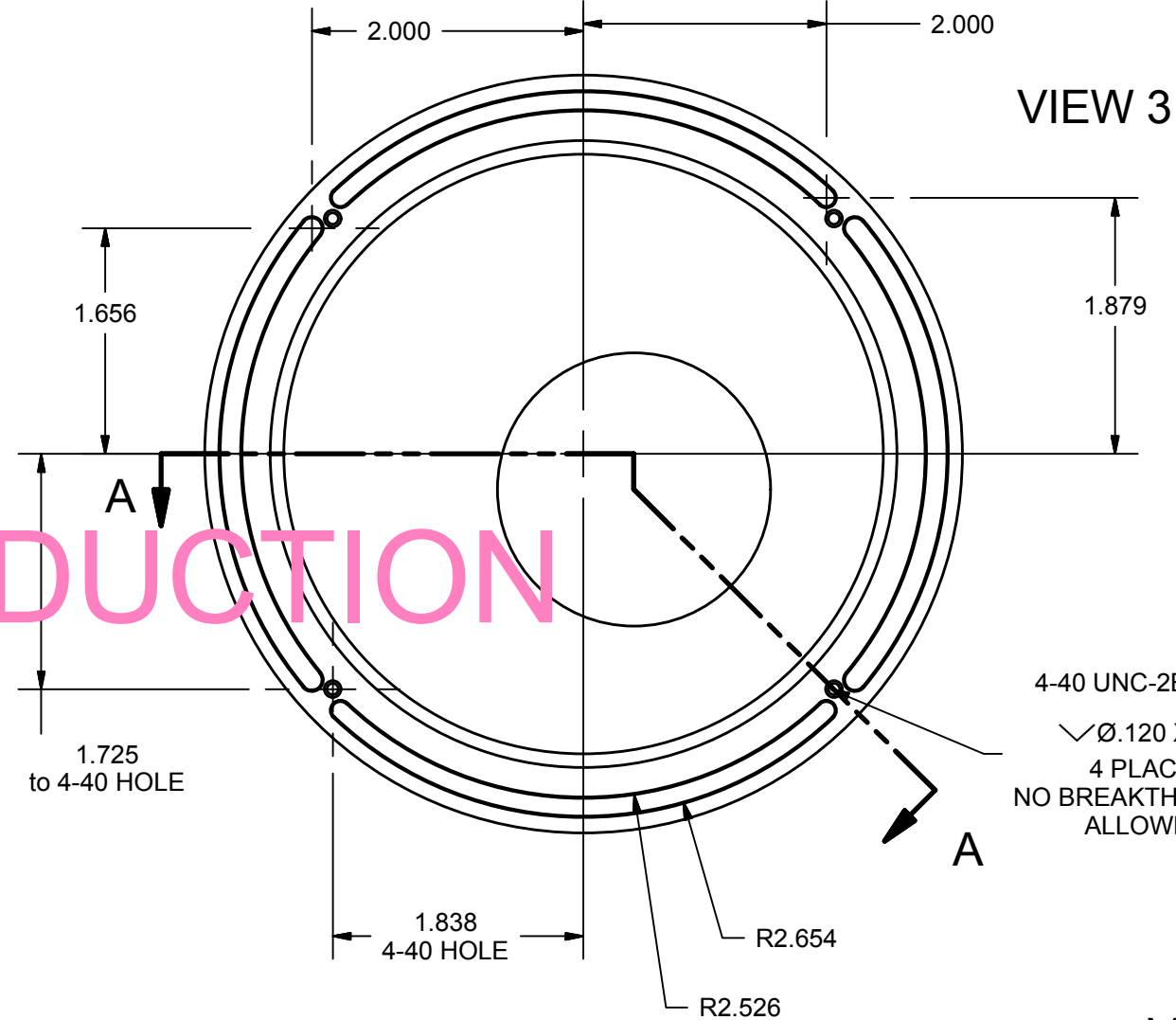

VIEW 6
SCALE 1 / 2

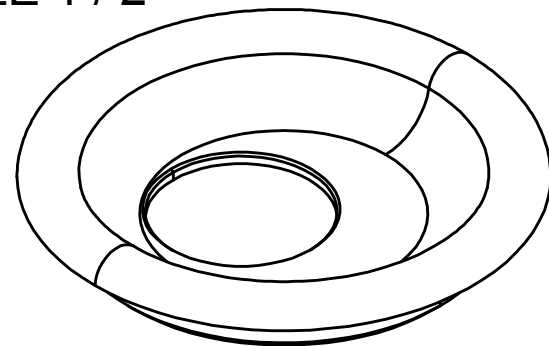

VIEW 5
SECTION A-A

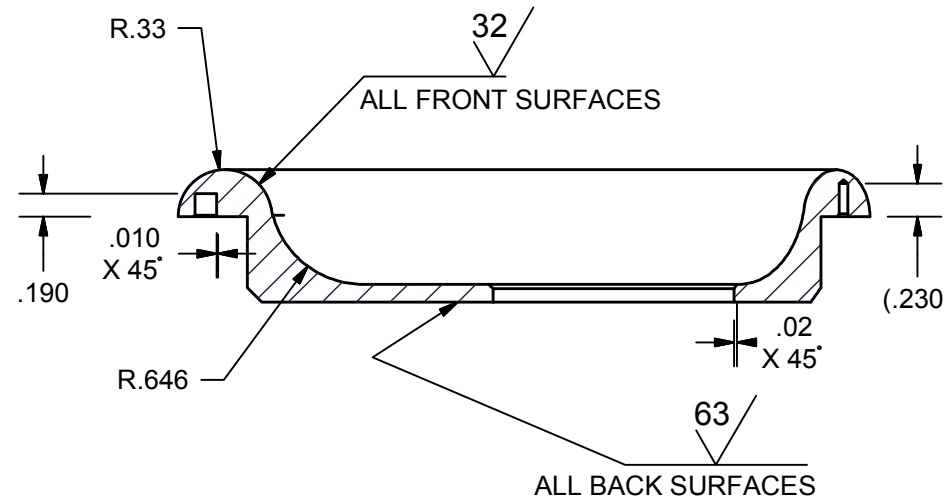

VIEW 4

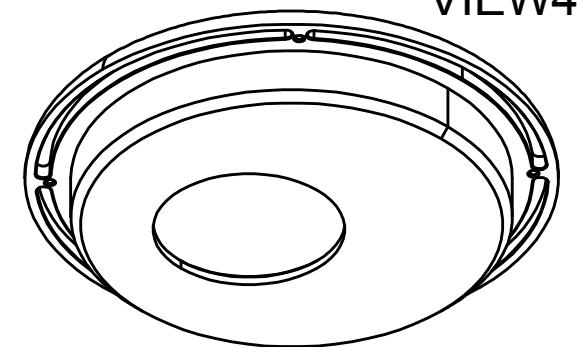

NOTES:

APPEARANCE PART!
NICE FINISH REQUIRED.
PART TO BE MACHINED ALL OVER.
QUALITY AND FINISH MUST BE BETTER THAN
OR EQUAL TO SAMPLE.
NO SCRATCHES ALLOWED
BREAK ALL SHARP EDGES .02 RAD.
BLACK ANODIZE

Rev A 12/20/09 Im Changed 4-40 Tapped hole.
Rev B 1/10/10 Im Changed 2.00 Dia. Hole
Rev C 10/10/11 Im Clarified Surface Callouts.

TOLERANCES:
X.XXX ± 0.005"
X.XX ± 0.010"
X.X ± 0.015"
ANGULAR
± 0.5 DEGREE

DRAWN Loren	6/20/2008
SCALE	
DLT #	DLT-0026
MATERIAL	6061 ALUM
SHEET 1 OF 1	
SURFACE FINISH	AS NOTED

Cambridge Precision Machining PORTLAND, OREGON PHONE: 503.624.1937 FAX: 503.624.1119 info@cambridgemachine.com	
Copyright 2007 Cambridge Precision. THIS DOCUMENT AND COPYRIGHT THEREIN ARE THE SOLE PROPERTY OF Cambridge Precision. AND MAY NOT BE USED, COPIED, OR DISCLOSED TO ANY THIRD PARTY WITHOUT WRITTEN AUTHORIZATION FROM Cambridge Precision.	
SIZE B	DWG NO DLT-0026 Cover, SW For Web
DO NOT SCALE. CAD FILES ARE AVAILABLE FOR THIS DRAWING. BREAK ALL SHARP EDGES .01" PACKAGE AND PROTECT AT ALL TIMES	

NOT FOR PRODUCTION